

MOTORS

DC MOTORS.....	A317
AC MOTORS.....	A318
SERVOMOTORS.....	A321
STEP MOTORS.....	A322
MINIATURE MOTORS.....	A322
GEARMOTORS.....	A323
MOTOR ENCLOSURES.....	A323
MOTOR PROTECTION.....	A325
MOTOR EFFICIENCIES.....	A326
INDUCED BEARING CURRENTS.....	A327
MOTORS ADVERTISING.....	A328

Most rotary motion applications today depend on motors. Electric motors are dominant, though air and hydraulic motors are preferred in some applications, and engines or turbines drive others.

Several types of electric motors turn shafts: dc, ac, servo, and step motors. Also, a motor may be just a motor or it may be a gearmotor; that is, it may have an integral geared speed reducer. Air motors are usually rotary vane or piston type; hydraulic motors are rotary vane, piston, or gear type. Each has operating characteristics inherent to its basic design. Thus, motor selection is often a process of matching application requirements to performance parameters of the various types, then selecting the most compatible.

Performance, however, is not the only criterion in motor selection. To optimize selection, choose an enclosure that protects the inner workings of the motor from the environment. Moreover, you must consider the best mounting arrangement, such as base

or flange mount. Also, consider ways to protect the motor from overloads and line fluctuations.

The following discussion deals with electric motors for rotary motion. For electric motors for linear motion, see the Linear Motion Devices Product Department in this handbook.

DC MOTORS

Direct current motors are used in many industrial applications that require adjustable speed.

In uses requiring quick stops, a dc motor can minimize the size of a mechanical brake or make it unnecessary. This is done by dynamic braking (motor-generated energy fed to a resistor grid), or by regenerative braking (motor-generated energy returned to the ac supply).

DC motor speed can be controlled smoothly down to zero, followed immediately by acceleration in the opposite direction (without power circuit switching). Also, due to high torque-to-inertia ratio, dc motors respond quickly to control-signal changes.

Motor types

DC motors in all but fractional and low integral horsepower sizes (generally below 15 hp), have wound fields and are categorized as shunt-wound, series-wound, or compound-wound motors. In fractional and low integral horsepower sizes, permanent magnets are used instead of wound fields in many motor designs.

Shunt-wound motors — Stabilized shunt-wound motors are oper-

ated from adjustable voltage power supplies, Figure 1. A stabilizing winding (a small series field) helps prevent speed increases as load increases at weak field settings, Figure 2. This winding has drawbacks in reversing applications, however, because winding

direction relative to the shunt winding must be reversed when armature voltage is reversed. Here, reversing contactors must be used. Where fast reversing is needed, the stabilizing winding is omitted, and the motor is designed for stable operation.

Permanent-magnet motors — Operating characteristics of permanent-magnet motors are similar to those of shunt-wound types. Field flux, however, is provided by permanent magnets instead of current in a winding. Motor torque is directly proportional to armature current over the motor's speed range. Compared with shunt-wound motors, permanent-magnet motors weigh less and are more economical to operate because no power is needed to support a field.

Series-wound motors — As its name implies, this motor has a field that is in series with the armature,

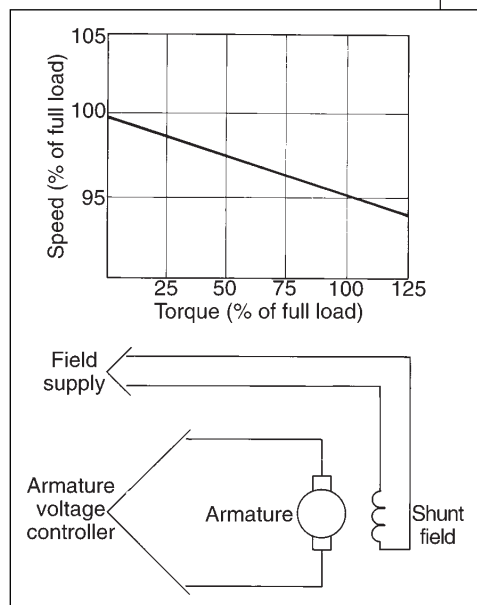

Figure 1 — Typical speed-torque curve and circuit for shunt-wound dc motor.

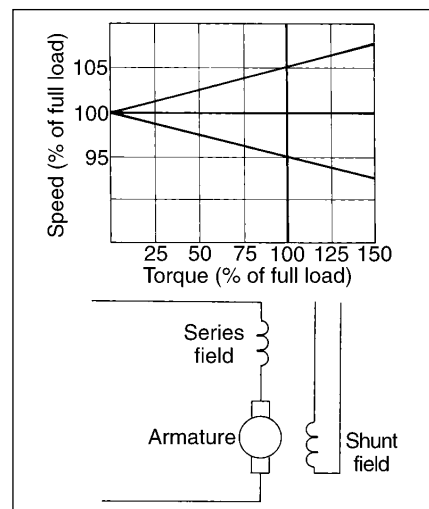

Figure 2 — Typical speed-torque curve and circuit for a shunt-wound dc motor with various series stabilizer windings.

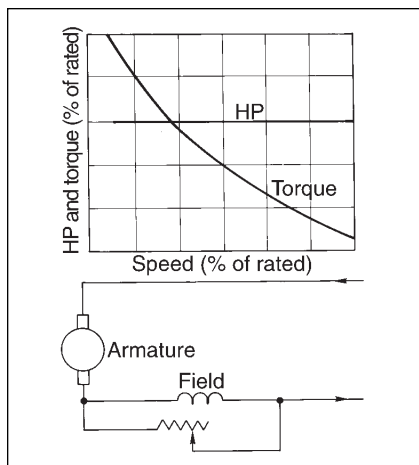

Figure 3 — Typical speed-torque-horsepower characteristics and circuit for a series wound dc motor.

Figure 3. These motors are often used to drive high starting torque loads, such as traction vehicles. Torque varies approximately as the square of current. An increase in armature current is accompanied by a like increase in field current. At rest, the torque is highest because no counter electromotive force (CEMF) is generated by the armature. As the armature gains speed, the CEMF rises, reducing the effective voltage, current, and torque. As the motor shaft load increases, the armature slows to provide sufficient voltage and current to match the load torque. If the load is removed, the motor will race dangerously.

Compound-wound motor — Both shunt and series field windings are used in compound motors. By adjusting strength and direction of the series winding relative to the shunt winding, speed-torque characteristics can be made to approximate those of series or shunt motors.

Controlling dc motors

DC motor speed is controlled by armature-voltage control, shunt-field control, or a combination of the two.

Armature-voltage control — The type of control varies the voltage applied to the armature, while field current is maintained constant from a separate source. Speed is proportional to CEMF, which is equal to the applied voltage minus the armature circuit IR drop. At rated current, the torque remains constant regardless of the speed (since the magnetic flux is constant) and, therefore, the motor has constant torque capability over

its entire speed range.

Horsepower varies directly with speed. As the speed of a self-ventilated motor is lowered, it loses ventilation and cannot be loaded with quite as much armature current without exceeding the rated temperature rise. Therefore, to obtain full load torque at low speeds, motors are oversized or auxiliary blowers are added for sufficient cooling.

Shunt-field control — By weakening shunt-field current, motor speed is altered, thus increasing speed and reducing output torque for a given armature voltage. Field control is good only for obtaining speeds greater than base speed (the no-load speed with full field strength). Maximum speed range by field control is about 5:1, and this occurs for only low base speed motors.

Because the rating of a dc motor is limited by heating, the maximum permissible armature current is nearly constant over the field-weakened speed range. This means that, at rated armature current, output torque varies inversely with speed, and the motor has constant-horsepower capability over this speed range.

Selecting dc motors

Choosing a dc motor type and associated equipment for a given application requires consideration of several factors.

Speed range — The minimum and maximum speeds for an application determine the motor base speed.

Allowable speed variation — Applications requiring constant speed at all torque values should use a shunt-wound motor. If speed changes with load and speed variation must be minimized to less than 2%, a regulator employing tachometer feedback must be used.

Torque requirements — The torque requirements at various operating speeds should be determined. Many applications are essentially constant torque, such as conveyors. Others, such as centrifugal blowers, require torque to vary as the square of the speed. In contrast, machine tools and center winders are constant horsepower, with torque decreasing as speed increases. Thus, the speed-torque relationship determines the most economical motor.

Reversing — This operation affects the power supply and control. When the motor cannot be stopped for switching series fields before reverse operation, compound and stabilizing windings should not be used if full load torque is needed in both directions. Bi-directional operation may also affect brush adjustments.

Duty rating — DC motors carry one of three ratings:

- Continuous duty is applied to motors that will continuously dissipate all the heat generated by internal motor losses without exceeding rated temperature rise.

- Definite time, intermittent duty motors will carry rated load for specified time without exceeding rated temperature rise. These motors must be allowed to cool to ambient before load is repeated.

- Indefinite time, intermittent duty is usually associated with some RMS load of a duty-cycle operation.

Peak torque — The peak torque that a dc motor delivers is limited by that load at which damaging commutation begins. Brush and commutator damage depends on sparking severity and duration. Therefore, peak torque depends on the duration and frequency of occurrence of the overload. Peak torque is often limited by the maximum current that the power supply can deliver.

Motors can commutate greater loads at low speed without damage. NEMA standards specify that dc machines must deliver at least 150% rated current for one minute at any speed within rated range, but most motors exceed this requirement.

Heating — The temperature of a dc motor is a function of ventilation and losses in the machine. Some losses — core, shunt-field, and brush-friction — are independent of load, and vary with speed and excitation.

Several methods can predict operating temperature. The best method is to use thermal capability curves available from the manufacturer.

AC MOTORS

AC motors can be divided into two major categories: asynchronous and synchronous.

The induction motor is the most common form of asynchronous motor and is basically an ac transformer with a rotating secondary. The pri-

mary winding (stator) is connected to the power source, and the shorted secondary (rotor) carries the induced secondary current. Torque is produced by the action of the rotor (secondary) currents on the air gap flux.

The synchronous motor resembles a dc motor turned inside out, with the permanent magnets mounted on the rotor. As an alternative, some are constructed using a wound rotor excited by a dc voltage through slip rings. The flux created by the current-carrying conductors in the stator rotates around the inside of the stator in order to achieve motor action.

Induction motors

These motors are probably the simplest and most rugged of all electric motors. They consist of two basic electrical assemblies: the wound stator and the rotor assembly.

The rotor consists of laminated, cylindrical iron cores with slots for receiving the conductors. On early motors, the conductors were copper bars with ends welded to copper rings known as end rings. Viewed from the end, the rotor assembly resembles a squirrel cage, hence the name "squirrel-cage" motor is used to refer to induction motors. In modern induction motors, the most common type of rotor has cast-aluminum conductors and short-circuiting end rings. The rotor turns when the moving magnetic field induces a current in the shorted conductors. The speed at which the magnetic field rotates is the synchronous speed of the motor and is determined by the number of poles in the stator and the frequency of the power supply.

$$N_s = \frac{120f}{P}$$

Where:

N_s = synchronous speed

f = frequency

P = number of poles

Synchronous speed is the absolute upper limit of motor speed. At synchronous speed, there is no difference between rotor speed and rotating field speed, so no voltage is induced in the rotor bars, hence no torque is developed. Therefore, when running, the rotor must rotate slower than the magnetic field. The rotor speed is just slow enough to cause the proper amount of rotor current to flow, so that the resulting torque is sufficient to overcome windage and friction losses, and drive the load. This speed difference between the rotor and magnetic field, called slip, is normally referred to as a percentage of synchronous speed:

$$s = \frac{100(N_s - N_a)}{N_s}$$

Where:

s = slip

N_s = synchronous speed

N_a = actual speed

Polyphase motors — NEMA classifies polyphase induction motors according to locked rotor torque and current, breakdown torque, pull up torque, and percent slip.

- Locked rotor torque is the minimum torque that the motor develops at rest for all angular positions of the rotor at rated voltage and frequency.

- Locked rotor current is the steady state current from the line at rated voltage and frequency with the rotor locked.

- Breakdown torque is the maximum torque that the motor develops at rated voltage and frequency, without an abrupt

drop in speed.

- Pull up torque is the minimum torque developed during the period of

acceleration from rest to the speed that breakdown torque occurs.

Figure 4 illustrates typical speed-torque curves for NEMA Design A, B, C, and D motors.

- Design A motors have a higher breakdown torque than Design B motors and are usually designed for a specific use. Slip is 5%, or less.

- Design B motors account for most of the induction motors sold. Often referred to as general purpose motors, slip is 5% or less.

- Design C motors have high starting torque with normal starting current and low slip. This design is normally used where breakaway loads are high at starting, but normally run at rated full load, and are not subject to high overload demands after running speed has been reached. Slip is 5% or less.

- Design D motors exhibit high slip (5 to 13%), very high starting torque, low starting current, and low full load speed. Because of high slip, speed can drop when fluctuating loads are encountered. This design is subdivided into several groups that vary according to slip or the shape of the speed-torque curve. These motors are usually available only on a special order basis.

Wound-rotor motors — Although the squirrel-cage induction motor is relatively inflexible with regard to speed and torque characteristics, a special wound-rotor version has controllable speed and torque. Application of wound-rotor motors is markedly different from squirrel-cage motors because of the accessibility of the rotor circuit. Various performance characteristics can be obtained by inserting different values of resistance in the rotor circuit.

Wound rotor motors are generally started with secondary resistance in the rotor circuit. This resistance is sequentially reduced to permit the motor to come up to speed. Thus the motor can develop substantial torque while limiting locked rotor current. The secondary resistance can be designed for continuous service to dissipate heat produced by continuous operation at reduced speed, frequent acceleration, or acceleration with a large inertia load. External resistance gives the motor a characteristic that results in a large drop in rpm for a fairly small change in load. Reduced speed is provided down to about 50%,

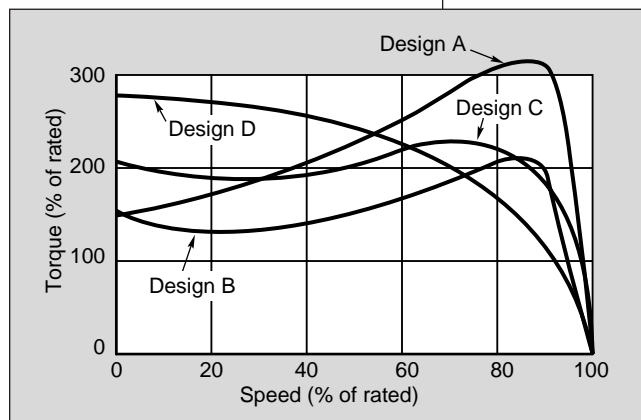

Figure 4 — Typical speed-torque characteristics for Design A, B, C, and D motors.

rated speed, but efficiency is low.

Single-phase motors — These motors are commonly fractional-horsepower types, though integral sizes are generally available to 10 hp. The most common single phase motor types are shaded pole, split phase, capacitor-start, and permanent split capacitor.

- *Shaded pole motors* have a continuous copper loop wound around a small portion of each pole, Figure 5. The loop causes the magnetic field through the ringed portion to lag behind the field in the unringed portion. This produces a slightly rotating field in each pole face sufficient to turn the rotor. As the rotor accelerates, its torque increases and rated speed is reached. Shaded pole motors have low starting torque and are available only in fractional and subfractional horsepower sizes. Slip is about 10%, or more at rated load.

- *Split phase motors*, Figure 6, use both a starting and running winding. The starting winding is displaced 90

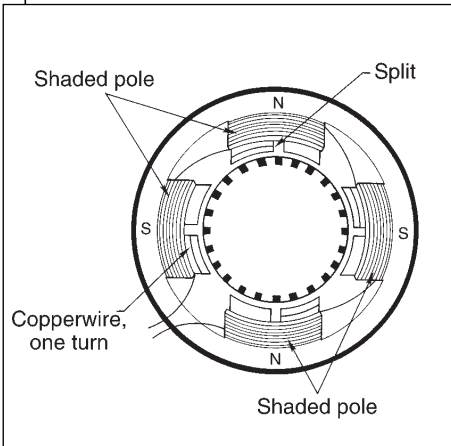

Figure 5 — Rings in shaded-pole motor distort alternating field sufficiently to cause rotation.

electrical degrees from the running winding. The running winding has many turns of large diameter wire wound in the bottom of the stator slots to get high reactance. Therefore, the current in the starting winding leads the current in the running winding, causing a rotating field. During startup, both windings are connected to the line, Figure 7. As the motor comes up to speed (at about 25% of full-load speed), a centrifugal switch actuated by the rotor, or an electronic switch, disconnects the starting winding. Split phase motors are considered low or moderate start-

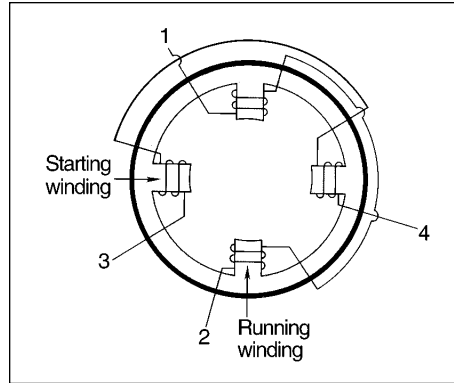

Figure 6 — Split-phase windings in a two-pole motor. Starting winding and running winding are 90 deg apart.

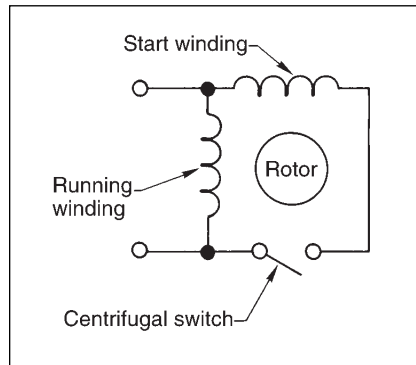

Figure 7 — Split-phase start induction motor.

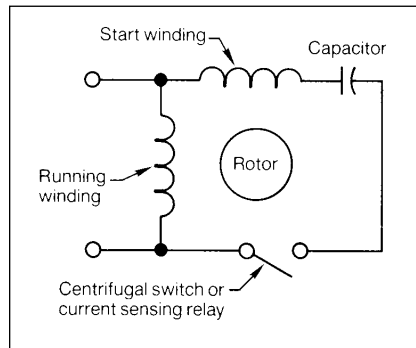

Figure 8 — Capacitor-start motors are similar to split-phase motors.

ing torque motors and are limited to about $\frac{1}{3}$ hp.

- *Capacitor-start motors* are similar to split phase motors. The main difference is that a capacitor is placed in series with the auxiliary winding, Figure 8. This type of motor produces greater locked rotor and accelerating torque per ampere than does the split phase motor. Sizes range from fractional to 10 hp at 900 to 3600 rpm.

- *Split-capacitor motors* also have an auxiliary winding with a capacitor, but they remain continuously energized and aid in producing a higher

power factor than other capacitor designs. This makes them well suited to variable speed applications.

Synchronous motors

Without complex electronic control, synchronous motors are inherently constant-speed motors. They operate in absolute synchronism with line frequency. As with squirrel-cage induction motors, speed is determined by the number of pairs of poles and the line frequency.

Synchronous motors are available in subfractional self-excited sizes to high-horsepower direct-current-excited industrial sizes. In the fractional horsepower range, most synchronous motors are used where precise constant speed is required. In high-horsepower industrial sizes, the synchronous motor provides two important functions. First, it is a highly efficient means of converting ac energy to work. Second, it can operate at leading or unity power factor and thereby provide power-factor correction.

There are two major types of synchronous motors: nonexcited and direct-current excited.

Nonexcited motors — Manufactured in reluctance and hysteresis designs, these motors employ a self-starting circuit and require no external excitation supply.

- *Reluctance designs* have ratings that range from subfractional to about 30 hp. Subfractional horsepower motors have low torque, and are generally used for instrumentation applications. Moderate torque, integral horsepower motors use squirrel-cage construction with toothed rotors. When used with an adjustable frequency power supply, all motors in the drive system can be controlled at exactly the same speed. The power supply frequency determines motor operating speed.

- *Hysteresis motors* are manufactured in subfractional horsepower ratings, primarily as servomotors and timing motors. More expensive than the reluctance type, hysteresis motors are used where precise constant speed is required.

DC-excited motors — Made in sizes larger than 1 hp, these motors require direct current supplied through slip rings for excitation. The

direct current can be supplied from a separate source or from a dc generator directly connected to the motor shaft.

Synchronous motors, either single or polyphase, cannot start without being driven, or having their rotor connected in the form of a self-starting circuit. Since the field is rotating at synchronous speed, the motor must be accelerated before it can pull into synchronism. Accelerating from zero rpm requires slip until synchronism is reached. Therefore, separate starting means must be employed.

In self-starting designs, fractional horsepower motors use methods common to induction motors (split phase, capacitor-start, and shaded pole). The electrical characteristics of these motors cause them to automatically switch to synchronous operation.

Although dc-excited motors have a squirrel-cage for starting, the inherent low starting torque and the need for a dc power source requires a starting system that provides full motor protection while starting, applies dc field excitation at the proper time, removes field excitation at rotor pull-out, and protects the squirrel-cage windings against thermal damage under out-of-step conditions.

SERVOMOTORS

These motors are used in closed loop control systems in which work is the control variable, Figure 9. The digital controller directs operation of the motor by sending velocity command signals to the amplifier, which drives the motor. An integral feedback device (resolver) or devices (en-

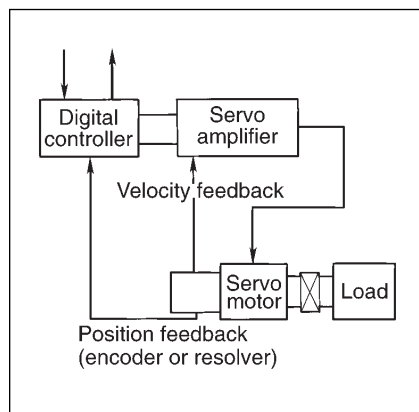

Figure 9 — Typical dc servosystem with either encoder or resolver feedback. Some older servosystems use a tachometer and encoder for feedback.

coder and tachometer) are either incorporated within the motor or are remotely mounted, often on the load itself. These provide position and velocity feedback that the controller compares to its programmed motion profile and uses to alter its velocity signal. The motion profile is a set of instructions programmed into the controller that defines the operation in terms of time, position, and velocity. The ability of the servomotor to adjust to differences between the motion profile and feedback signals depends greatly upon the type of controls and motors used. See the Controls and Sensors Product Department.

Three basic types of servomotors are used in modern servosystems: ac, based on induction motor designs; dc, based on dc motor designs; and ac brushless, based on synchronous motor designs.

AC servomotors

These are basically two-phase, reversible, induction motors modified for servo operation. They are used in applications requiring rapid and accurate response characteristics. To achieve these characteristics, these induction motors have small diameter, high resistance rotors. The small diameter provides low inertia for fast starts, stops, and reversals. High resistance provides nearly linear speed-torque characteristics for accurate control.

An induction motor designed for servo use is wound with two phases physically at right angles or in space quadrature. A fixed or reference winding is excited by a fixed voltage source, while the control winding is excited by an adjustable or variable control voltage, usually from a servoamplifier. The windings are often designed with the same voltage/turns ratio, so that power inputs at maximum fixed phase excitation, and at maximum control phase signal, are in balance.

The inherent damping of servomotors decreases as ratings increase, and the motors are designed to have a reasonable efficiency at the sacrifice of speed-torque linearity.

Induction type servomotors are available in fractional and integral horsepower sizes.

DC servomotors

DC servomotors are high performance motors normally used as prime movers in numerically controlled machinery or other applications where starts and stops must be made quickly and accurately. They have lightweight, low inertia armatures that respond quickly to excitation voltage changes. In addition, very low armature inductance in these motors results in a low electrical time constant (typically 0.05 to 1.5 ms) that further sharpens motor response to command signals.

DC servomotors are manufactured in permanent magnet, printed circuit, and moving coil (or shell) types. Each of these basic types has its own characteristics, such as physical shape, costs, shaft resonance, shaft configuration, speed, and weight. Although these motors have similar torque ratings, their physical and electrical constants vary considerably. The performance of the servomotor is as dependent on the control scheme used as much as the inherent characteristics of the motors themselves.

Brushless dc servomotors

Brushless dc motors resemble a dc shunt motor turned inside out. Permanent magnets, located on the rotor, or a wound rotor excited by dc voltage through slip rings, requires that the flux created by the current carrying conductors in the stator rotate around the inside of the stator in order to achieve motor action. The rotating field is obtained by placing three stator windings around the interior of the stator punching. The windings are then interconnected so that introducing a three-phase excitation voltage to the three stator windings (which are separated by 120 electrical degrees) produces a rotating magnetic field. This construction speeds heat dissipation and reduces rotor inertia.

The permanent magnet poles on the rotor are attracted to the rotating poles of the opposite magnetic polarity in the stator creating torque. As in the dc shunt motor, torque is proportional to the strength of the permanent magnetic field and the field created by the current carrying conductors. The magnetic field in the stator rotates at a speed proportional to the frequency of the applied voltage

and the number of poles.

The rotor rotates in synchronism with the rotating field, thus the name "synchronous motor" is often used to designate motors of this design. More recently, this motor design has been called an electrically commutated motor (ECM) due to its similarity to the dc shunt motor. In the dc shunt motor, the flux generated by the current carrying winding (rotor) is mechanically commutated to stay in position with respect to the field flux. In the synchronous motor, the flux of the current carrying winding rotates with respect to the stator; but, like the dc motor, the current carrying flux stays in position with respect to the field flux that rotates with the rotor. The major difference is that the synchronous motor maintains position by electrical commutation, rather than mechanical commutation.

STEP MOTORS

A step motor is a device that converts electrical pulses into mechanical movements. Conventional motors rotate continuously, but a step motor, when pulsed, rotates (steps) in fixed angular increments.

Step size, or step angle, is determined by the construction of the motor and the type of drive scheme used to control it. Traditionally, step resolution has ranged from 90 degrees (four steps per rev) to a fraction of a degree, though 15 degrees (12 steps per rev), to 1.8 degrees (200 steps per rev) has been most common. More recently, however, microstep motors have been introduced that are capable of .0144 degree steps (25,000 steps per rev). Microstep motors are hybrid 200 step per rev motors that are electrically controlled to produce 25,000 steps per rev.

Step motors are usually used in open loop control systems, Figure 10, though an encoder may be used to confirm positioning accuracy.

There are many types of step-motor construction. However, permanent magnet (PM) and variable reluctance (VR) are the most common types.

PM step motors

The permanent magnet step motor is also referred to as a synchronous inductor motor. It moves in steps when its windings are sequentially energized, or it can operate as a low speed synchronous motor when operated from a two-phase ac power source. Figure 11 illustrates a permanent magnet rotor surrounded by a two-phase stator. Two rotor sections (N and S) are offset by one half tooth pitch to each other. As energy is switched from phase 2 to phase 1, a set of rotor magnets will align with phase 1, and the rotor will turn one step. If both phases are energized simultaneously, the rotor will establish its equilibrium midway between steps. Thus, the motor is said to be half-stepping.

VR step motors

The variable reluctance (also termed "switched reluctance") step motor is also constructed with a toothed rotor and stator. There are not, however, any magnets in the rotor. Depending on the

stator design, two, three, or four phase windings may be used.

Microstep motors

Microstep motors are usually hybrid motors. The rotor consists of an arbor, bearings, and one, two, or three sets, or stacks, of toothed cylindrical magnets. The toothed stator is wound so that alternate poles are driven by two separate phase currents. This results in a 200 step per rev motor that, when the two windings are energized proportionately, enable the motor to make 125 intermediate steps between each full step. Thus, using digital logic control and bipolar pulse width modulation, the motor makes 25,000 microsteps per rev.

MINIATURE MOTORS

Filling the needs for a wider variety of power devices, new miniature motors are announced every day. Many are less than 1/2-in. diam, even with a gearhead, Figure 12. Typical applications include medical systems, semiconductor manufacturing, laser cutting systems, surface-mount assembly systems, winding machines, robotic handling equipment, micrometer positioners, motorized potentiometers, screwdrivers, scales, aircraft actuators, computer peripherals, bar code scanners, and many others.

To maximize the power-to-weight ratio, many miniature motors are built with more costly but higher strength magnets. Also, for reduced susceptibility to electrical noise, some are designed with relatively low inductance.

Manufacturers often indicate motor size with a Size designation of the diameter in 1/10s of an inch. Thus, a Size 30 motor has an outside diameter of 3 in.

For feedback, manufacturers offer a range of miniature optical and mag-

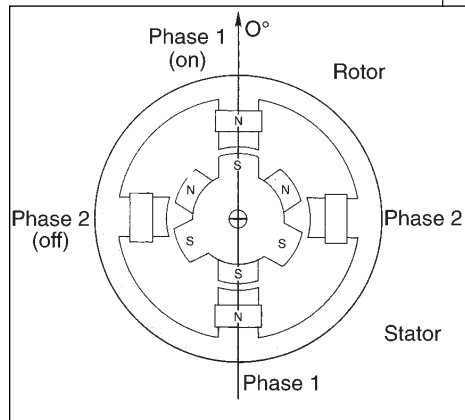

Figure 11 — Step motor with permanent magnet rotor.

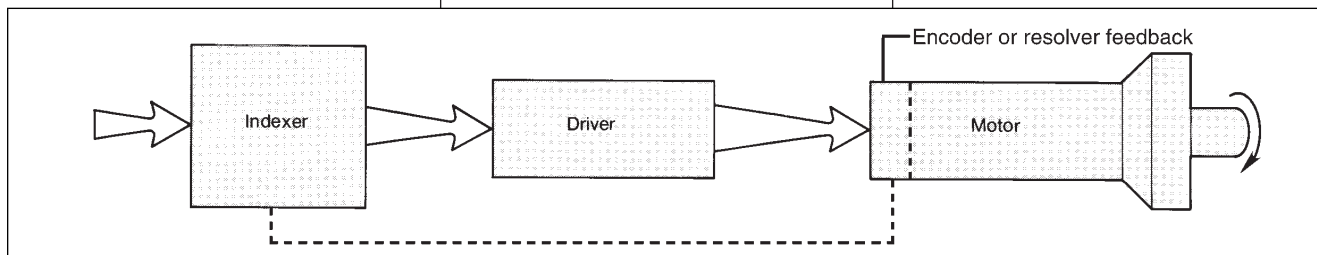

Figure 10—Typical step motor system. Precise step systems have feedback loop (dotted line) using encoders or resolvers.



Figure 12 — Typical of miniature motors, this dc motor is 0.511 in. in diam and 1.24 in. long. It has an output power rating of 2.5 W at 8,000 rpm. The construction consists of Neodymium magnets, precious metal brushes, and a moving-coil rotor that uses a Rhombic-wound winding for maximum winding density. A matching 0.511-in. planetary gearhead offers five ratios from 4:1 to 1,118:1 and torque capability to 0.35 Nm continuous and 0.53 Nm intermittent.

netic encoders, ac and dc tachometers, and resolvers. Some companies supply line-driver encoders for electrically noisy environments and for installations with long distances between the encoders and the motors.

Other miniature components offered for motion systems include miniature brakes, controls, and servo systems with appropriate software.

Size vs. capability

Some motors with diameters of less than 1 in. offer over 100 W. Other motors, such as a 48 Vdc motor, offer speeds to 100,000 rpm.

Not all the miniature motors are rotary devices. Miniature linear step motors are used in applications that require precise linear positioning. For some of these motors, resolution ranges from 0.008 to 0.000125 in. per full step.

Slightly different

Several miniature motor manufacturers use motor designs that differ from larger motors. For example, one design uses a hollow, ironless-core, rotor design, Figure 13, for low inertia and fast response. The rotor fits over a stationary magnet system. Only the copper coil moves, unlike larger motors where the whole coil and magnet system move. Such a design is 38 mm in diameter and is rated for 100 W.

GEARMOTORS

A gearmotor, Figure 14, consists of a motor and speed reducer in an integral assembly. The motor portion of the assembly can be either dc or ac-powered. The speed reducer portion can use spur, helical, or worm gears. Gearmotor sizes range from fractional to above 200 hp.

The main advantage of a gearmotor is that the driving shaft can couple directly to the driven shaft, thus in many situations making belts, chains, or separate speed reducers unnecessary. Also, because the motor and speed reducer are aligned during manufacture, field installation is simpler.

Starting and running torque must be considered separately because starting characteristics of the motor and gearing differ. Applications needing high breakaway torque require careful selection of the motor—split-phase polyphase, capacitor-start, and brush types have high starting torque.

The gearmotor manufacturer should analyze any application with high inertia. This problem is especially important with self-locking right-angle gearmotors. Because the rotor and load are rigidly connected

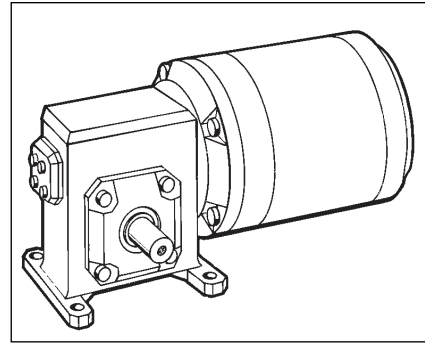

Figure 14 — Typical gearmotor in right-angle configuration.

by the gear train, both must stop in the same time. In severe cases, momentary power failure may be all that is necessary for a high-inertia load to destroy the gear train.

Overhung loads are applied to the output shaft of the gearmotor whenever the gearmotor is connected to the application by belts, chains, or gearing. Applications requiring cams, hoisting drums, or switches at the output shaft can also cause very high overhung loads on gearhead bearings.

It is inherent in gearmotors that overhung load capacity decreases as delivered torque increases.

MOTOR ENCLOSURES

NEMA standards MG1-1.25, 1-1.26, and 1-1.27 define more than 20 types of enclosures under the categories of open machines, totally enclosed machines, and machines with encapsulated or sealed windings.

Open machines — Very few open machines are made today. Most standard motors are drip-proof and guarded, Figure 15, or at least semi-guarded. To improve the protection offered by drip-proof enclosures, some manufacturers offer special processes or treatments to protect the windings and bearings.

Totally enclosed machines — Most totally enclosed machines are fan-cooled, Figure 16. However, some models in fhp ratings are totally enclosed and nonventilated. Totally enclosed motors are more expensive, but offer better protection. Outside ventilating air and contaminants are excluded from interior parts of a totally enclosed motor. The motor is not airtight, but usual entrances to the inte-

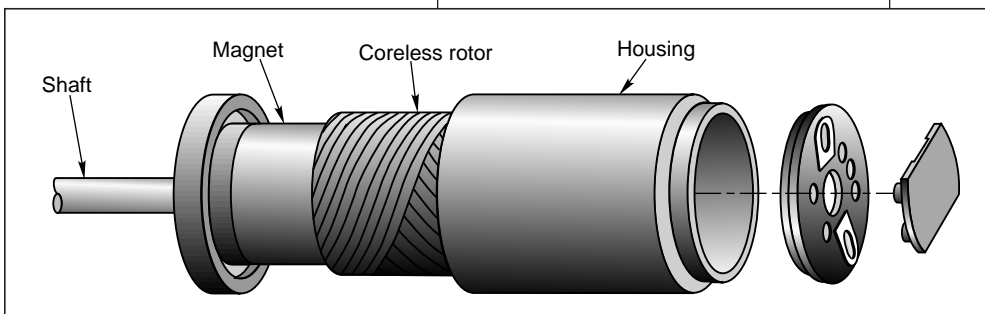

Figure 13 — Some miniature motors use a coreless motor design, also referred to as ironless core or moving coil. The concept replaces a rotating iron armature wound with copper wire with a light weight copper coil. This coil rotates around a stationary magnet system.

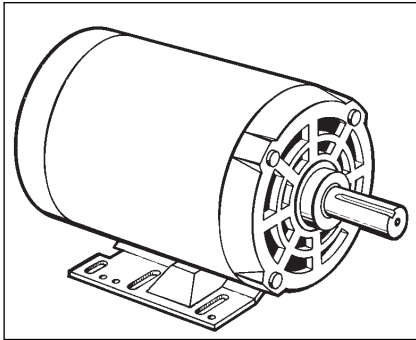

Figure 15 — Typical drip-proof and guarded enclosure.

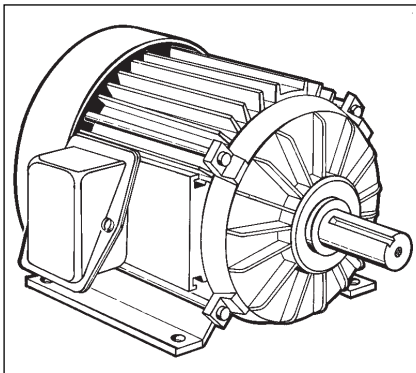

Figure 16 — Typical totally enclosed, fan-cooled enclosure.

rior, such as the conduit box, are gasketed. Clearances like those around shafts are kept as small as possible.

Explosion-proof machines — Hazardous atmospheres require special totally enclosed motors. Motors for these atmospheres are designed to standards established by Underwriters Laboratories (UL). Only after a motor has been examined and approved by UL can it be sold as an explosion-proof motor.

Washdown — For those applications that are subjected to washdowns with high-pressure liquid cleaners require more features to protect the motor from severe conditions. These are typically encountered in such industries as food processing plants and dairies. The motors are housed in a steel enclosure that is covered with an FDA approved epoxy paint or in a stainless-steel enclosure. Seals at every opening are selected to prevent fluids from entering the motor as well as out of the bearings. Inside, all parts are covered with epoxy paint or other material to retard corrosion, Figure 17.

Bakery service — For the baking industry, motors similar to the white washdown motors are rated for service according to Baking Industry

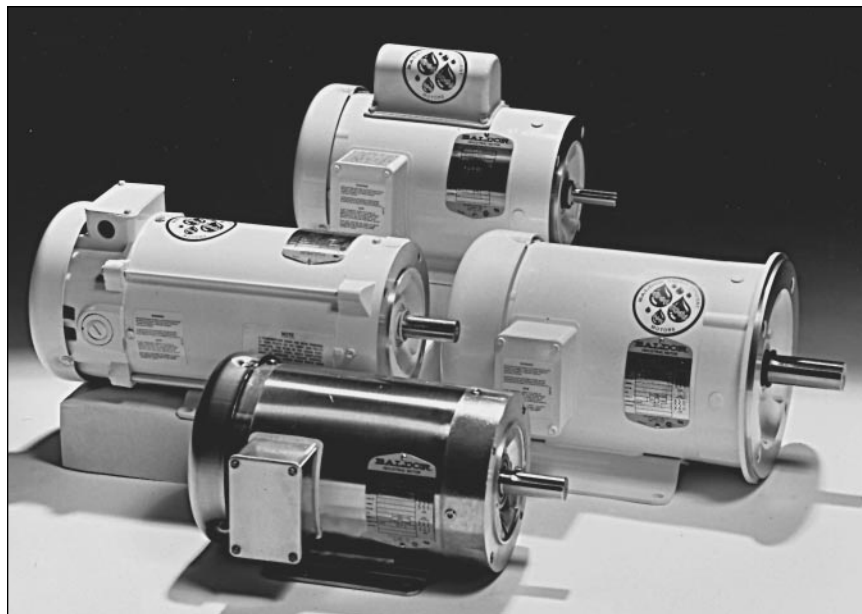

Figure 17 — Washdown duty motors include white dc motor (left), three-phase motor (right), single-phase motor (top) and the stainless steel motor in the foreground.

Sanitation Standards Committee (BISSC) requirements. Every bend is filleted to prevent material build-up in a sharp bend, fold, or crack. Typically the same internal and external protection is provided as is supplied with washdown motors, and the final finish is a glossy, smooth white.

Information on washdown and BISSC motors is excerpted from an article by Baldor in the March 1994 issue of PTD.

Frameless motors — Frequently designed into machine tools to power high-speed spindles, frameless ac motors are now finding acceptance in other machines that have space constraints or unusual mounting requirements.

Recent technological advancements — new cooling techniques, more precise feedback devices, and expanding use of CAD — are extending the popularity of frameless motors into more registration-oriented operations such as paper converting and printing.

Construction of frameless ac motors, electrically, is no different than conventional permanent-magnet and induction motors. The frameless designs can be controlled by the same drives as those used to control frame-type motors.

Mechanically, however, frameless motors are a horse of a different color. They are delivered as individual com-

ponents — a rotor, stator and feedback assembly, Figure 18, which are installed as an integral part of a machine, Figure 19.

Frameless motors typically have continuous torque ratings from 100 lb-in. to 10,000 lb-in. and speeds from 300 to 20,000 rpm.

Advantages include:

- Increased rigidity (stiffness). Overall machine stiffness is dependent on the cumulative stiffness of all mechanical elements between the motor rotor and load. These typically include belts, pulleys, gear sets or gearboxes, and couplings. In many applications, these can be eliminated

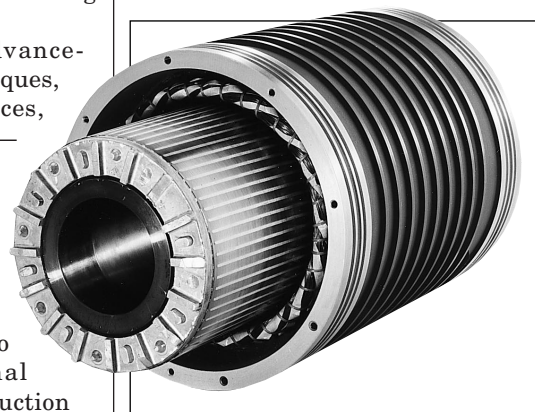

Figure 18 — In a frameless motor, the casing around the stator windings provides mechanical stability for the windings and a path for transmitting winding heat to the cooling medium — typically a liquid that circulates through the finned structure.

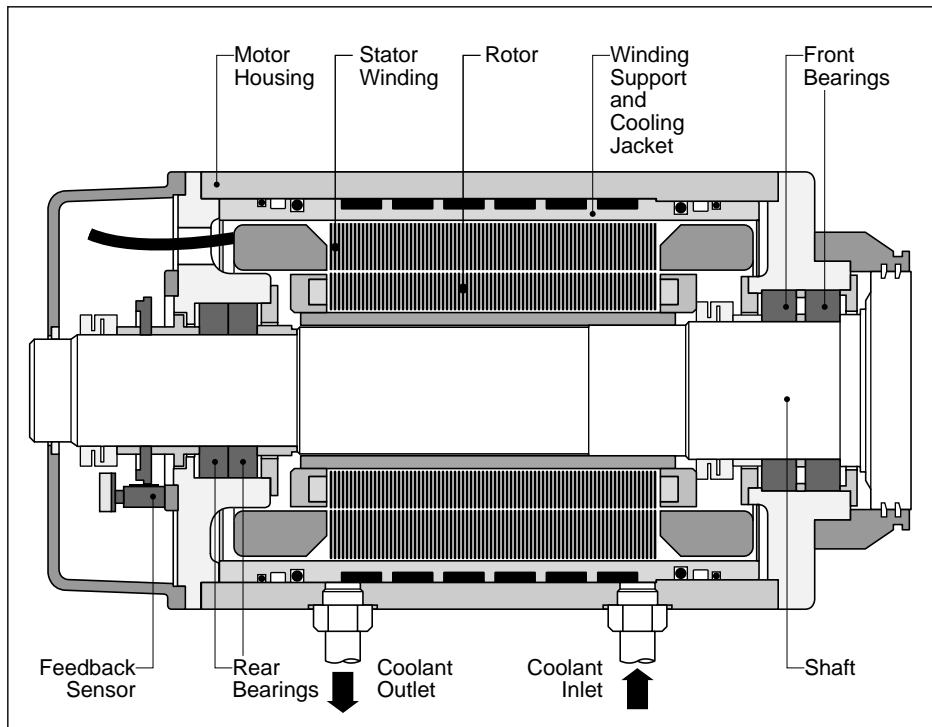

Figure 19 — A complete frameless motor assembly includes a rotor, stator, and feedback sensor supplied by the motor manufacturer. The machine manufacturer provides the bearings, shaft, housing, and cooling medium.

by direct coupling.

Moreover, shaft stiffness is a function of the cube of the shaft diameter. On frameless motors, the shaft diameter can be approximately three times greater than that of a conventional motor, thus giving 27 times more stiffness.

- Versatile motor cooling methods. Among them, fluid cooling enables a compact motor to deliver high power.

- Shafting options. Units can incorporate a shaftless rotor with a bore through it or with a hollow shaft. This design offers machine builders the freedom to configure a variety of shafting options. For example, material or process fluids can pass directly through a hollow shaft.

- Tailored bearing structure. Machine builders can tailor bearing structures to the precise needs of each machine. High-speed applications, such as spindles, can use a structure that minimizes bearing heat. Low-speed applications, such as rotary tables, can be designed to handle large radial or axial loads.

- Compact design. Frameless motors can be one-seventh the volume of conventional framed motors with the same power rating,

Are they for you? Although frame-

less motors offer many benefits, they are not the right solution for every application. For example, if you are building one or two machines, it will probably be a waste of your time to design a frameless motor into a machine. Generally, doing so takes 50 to 100 machines to pay for the initial design investment.

Information on frameless motors is excerpted from an article by Indramat in the November 1995 issue of PTD.

MOTOR PROTECTION

Motor longevity can often be improved by protecting the motor from overheating and from fluctuations in the incoming power distribution system.

Overheating

Motors can be protected from overheating by two basic methods — indirect and direct. Each offers advantages. In some cases, both methods should be used to assure maximum protection.

Indirect method — the most common method of three-phase motor protection simulates the internal motor conditions by sensing current to

the motor and the general conditions surrounding the motor.

- **Thermal overload relays**, Figure 20, are the most frequently used method of indirect protection. In operation, motor current passes through the heater in each overload relay (three relays are used for three-phase motors). An increase in motor load increases current both in the motor and in the relay's heater. If heater temperature reaches a predetermined point, the overload contacts open, turning off the motor.

- **Magnetic overload relays** contain a fluid dashpot to retard the trip time and approximate the allowable motor heating curve. However, magnetic units are unaffected by cumulative motor heating though thermal overload relays are. Also, magnetic units are not ambient-temperature compensated.

- **Differential current systems** usually serve motors of 500 hp or more, and use three current transformers. Each transformer senses the sum of the currents flowing through two wires of the same phase. This sum is zero during normal operation. If a fault occurs—such as shorted turns or voltage imbalance—the sum of the currents through one or more current transformers becomes significant. The control scheme senses this condition and turns off the motor or provides a warning signal.

Direct method — Used for protecting small single-phase motors up to high-horsepower units, direct methods of motor protection sense the temperature within the motor. Various methods offer different levels of protection. Almost all direct methods do a better job of protecting the stator than the rotor. That is the reason for sometimes using more than one method, as discussed previously.

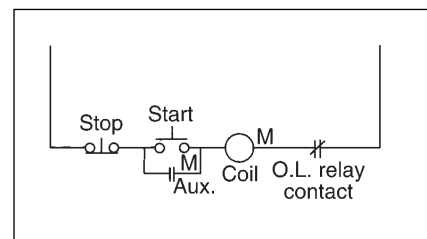

Figure 20 — Typical control circuit with NC overload relay contact in series with motor starter coil.

Reflected wave produced by A-S drives

Insulated gate bipolar transistors (IGBTs) let adjustable-speed drives turn voltage on and off 18,000 to 20,000 times a second. To do this means the voltage rise time is short, usually less than a microsecond. These short rise times combined with long power lines between the drive and controller can produce voltage reflections, also called reflected waves that have high peak voltages. If the voltages are large enough, they will generate potentially destructive stresses in the motor insulation. This phenomenon is not widespread, but users should be aware of it.

Reflected wave phenomenon primarily affects 460-V and 575-V, IGBT-based drives. Generally, 230-V applications are unaffected because the reflected wave amplitudes are low while the typical motor insulation is the same as a 460 V-motor.

The fast switching capabilities of various drive switching devices, especially IGBTs; long cable lengths between motors and drives; and mismatched surge impedance between

the cable and the motor contribute to the existence of this phenomenon. In addition, the insulation process for motor windings may leave microscopic voids in the coating. These holes can be insulation failure points when voltage peaks are impressed on the stator winding by a reflected wave, since as much as 60 to 80% of the voltage can be distributed across the first turn of the motor winding.

At this time, conclusive data is not available to determine the exact cause of insulation failure; motor manufacturers are split on what situations result from the reflected wave phenomenon. But there are solutions.

- Provide a motor with insulation that can withstand the typical amplitudes of reflected waves.
- Keep cable length short.
- Install a filter at the drive output.
- Install a terminating device that will keep the amplitude of the reflected wave below potentially destructive levels.

- *Inherent* is the simplest of the direct methods. Its device mounts in the motor end shield. Used in motors from fractional through 10 hp, an internal bimetal strip responds to surrounding temperature — the result of ambient temperature, internal motor temperature, internal motor heating, and the heat dissipated by a resistive heater through which current passes. The bimetal strip operates one or three contacts, depending on motor requirements.

- *Thermostats* are also made with bimetal-operated, snap-action contacts. One or more thermostats installed on motor-winding end turns sense true winding temperature. However, the unit is insulated from the winding and has significant mass to heat. This combination induces a thermal lag that makes the device suitable for sensing slowly changing temperatures. Thermostats are often combined with thermal overload relays, which offer better protection against locked rotor conditions.

Voltage surge protection

A voltage spike, or surge, can dam-

age a motor almost instantly. Lightning can cause severe motor damage even if transformers and lightning arrestors are installed on the incoming distribution system. Power companies frequently use power-factor correcting capacitors in distribution systems. If these capacitors are switched, large voltage transients can be generated, especially if proper snubbers are not installed. Insulation failures in the electrical system other than in the motor can produce voltage spikes five times the normal line-to-ground crest value. With these possibilities for voltage spikes, it is imperative that proper transient suppression networks be installed on equipment essential to an operation and on motors operating at 2300 V or more. For more on a specific type of voltage spike, reflected wave phenomenon, see the box, "Reflected wave produced by A-S drives." Two types of protection are commonly used — lightning arrestors and surge capacitors.

- Arrestors limit the maximum voltage across the motor terminals.
- Capacitors limit the rate of voltage rise. If this rate is not limited, the first few motor windings must absorb a surge,

possibly causing insulation failure. With capacitors installed, the rate of rise is reduced and the surge is more evenly distributed across the entire winding.

Programmable units

Programmable motor protection units are designed to protect large motors, generally of 500 hp or more, and motors that are essential in a system or process.

Typically, the operator or programmer inputs specific motor data, such as full-load and locked-rotor time, allowable acceleration time, allowable number of starts in a specified time, and several other electrical parameters, plus allowable winding and bearing temperature.

The programmer can also establish what action the unit will take in the event of a fault—indicate an alarm, shut down the motor, or initiate an orderly process shutdown.

For efficient energy management, some programmable units give instrument outputs to indicate lapsed running time, energy consumption, power factor, and power.

MOTOR EFFICIENCIES

The Energy Act of 1992 defines new efficiency levels for several electrical devices including motors. By 1997, however, motor manufacturers will no longer be able to offer standard-efficiency motors. It is assumed that as motors wear out, replacement motors will be the high-efficiency offerings.

High-efficiency motors are built to reduce motor energy loss. Improvements in several areas, Figure 21, increase motor service life:

- Larger-diameter wire, increasing the volume of copper by 34 to 40%. This change reduces copper losses that result naturally from current passing through the copper-wire windings.
- Larger wire slots to accommodate larger wire. This reduces the amount of active steel in each steel lamination.
- Longer rotor and stator core to compensate for the loss of steel and the resultant need to add more laminations.
- High-grade silicon steel laminations approximately 0.018 in. thick, having an electrical loss of 1.5 W/lb. The chemical makeup and thinner gage of the laminations, plus a coating of inorganic insulation on each piece, reduce eddy current losses. Special an-

Stator has longer core of lower-loss electrical steel laminations, and larger slots to accommodate the heavier-gage copper wire

Low-resistance rotor with special slot designs and high-grade aluminum rotor bars improve performance and efficiency

Air gap between rotor and stator is tighter, reducing magnetic flux losses

Heavier-gage copper wire windings

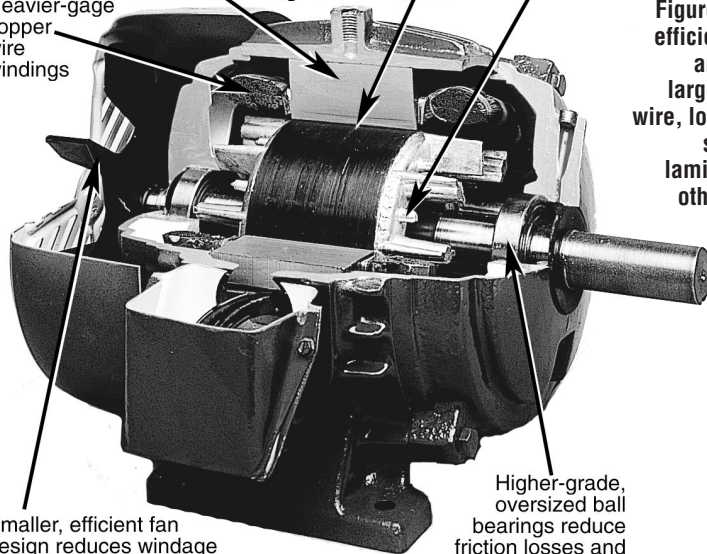

Smaller, efficient fan design reduces windage losses and noise levels

Higher-grade, oversized ball bearings reduce friction losses and increase bearing life

Figure 21 —High efficiency motors are built with larger-diameter wire, longer rotors, silicon steel laminations and other features.

nealing and plating of rotor and stator components and use of high-purity cast aluminum rotor bars reduce hysteresis losses.

- Higher-grade bearings reduces friction loss.
- Smaller, more efficient designs reduce windage losses in fan-cooled motors.
- Tighter tolerances and more stringent manufacturing-process control reduce losses from unplanned conducting paths and stray load phenomena.

These design changes also result in cooler running motors. Cooler operation lengthens a motor's service life in two ways. For every 10 C reduction in temperature, motor insulation life doubles; high-efficiency motors tend to operate 10 to 20 C cooler than standard-efficiency motors.

The motors that must meet the new efficiency levels include: All motors made in or exported to the U.S., including all motors sold as part of a piece of equipment; general purpose motors; motors rated from 1 - 250-hp; T-Frame; single speed; foot mounted; polyphase; NEMA designs A & B; continuous rated; 230/460 volts; constant 60-Hz frequency.

Exceptions include special purpose and definite purpose motors.

Efficiency ratings will be on the mo-

tor nameplate. A recent efficiency labeling standard requires that premium-efficiency motors carry the NEMA nominal efficiency rating on the label.

INDUCED BEARING CURRENTS

Problems produced by electric currents passing through the bearings in an ac motor (especially motors rated in the hundreds of horsepower) has been recognized since the 1920s. Today, however, adjustable-speed (A-S) drives and plants generating their own power are putting a modern twist to this problem that significantly shortens bearing life.

Causes of induced shaft voltages

Magnetic imbalances and harmonics in the power line are the primary causes of induced shaft voltages that, in turn, produce damaging bearing currents. Other causes include improperly grounded electric arc welding and static electricity from manufacturing processes, such as pumping or compressing applications.

Magnetic imbalances, which are produced by the motor design or its

application, are considered the primary causes of bearing currents, especially in motors in the hundreds of horsepower. These imbalances are typically caused by some form of non-uniform magnetic flux paths.

Harmonics in the voltage supplied to the motor are becoming more common because more facilities are generating their own power, more motors are powered by adjustable-speed drives, and more drives now use IGBT rather than SCR and GTO technologies in the drive inverter section. As harmonic content in an adjustable-speed motor-drive system increases, motors that previously had no problem with shaft currents may begin to develop rapid bearing failures.

This shaft voltage seeks a complete circuit through its two bearings to ground, or through its outboard bearing and the connected machinery. Unless prevented from reaching high levels, over 0.5 V, it can cause chemical changes in the insulating grease, breaking it down and thereby making the grease act like an electrolytic in a capacitor.

When a motor operates on sinusoidal power, a safe low level for voltage along the length of the shaft is less than 0.1 V. If a motor operates off an adjustable-speed power, high-frequency transient-voltage spikes can cause this voltage to measure appreciably higher.

Determining the problem

There are two methods to determine if bearing currents are the cause of unexpected motor bearing failure: measure the shaft voltage or examine the bearings.

All motors have some level of shaft voltage. Above a certain level, shaft voltage is a failure indicator. Generally end-to-end shaft voltage should be less than 0.5 V. Normally, voltage levels below this will not cause harmful bearing currents. Engineers can measure the shaft voltage with any voltmeter that has an impedance of 10,000 ohms per volt or more.

When examining the bearings, look for specific types of damage. Bearing damage results when current is broken at the contact surfaces between rolling elements and raceways, Figure 22. The size of the damage points depends on the magnitude of the induced voltage, the impedance of the current

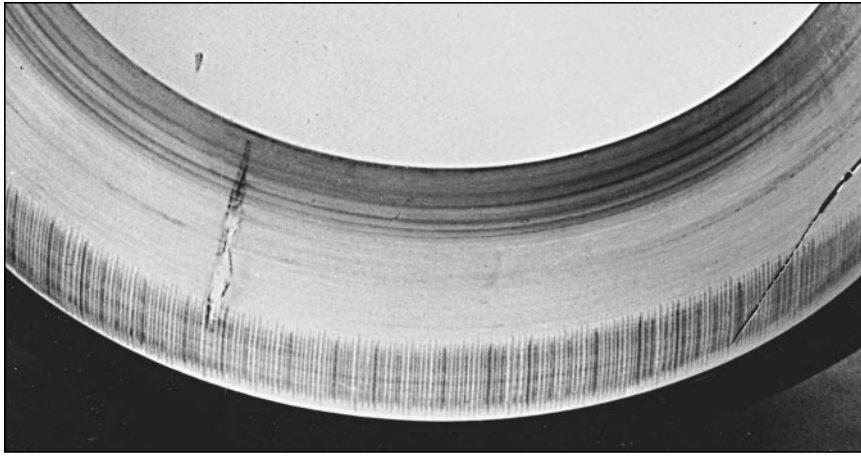

Figure 22 — When current is broken at the contact surface between the rolling elements and the raceways, it produces arcing damage.



Figure 23 — Electrical pits are another indication of bearing currents. If left unchecked, this will eventually result in fluting.

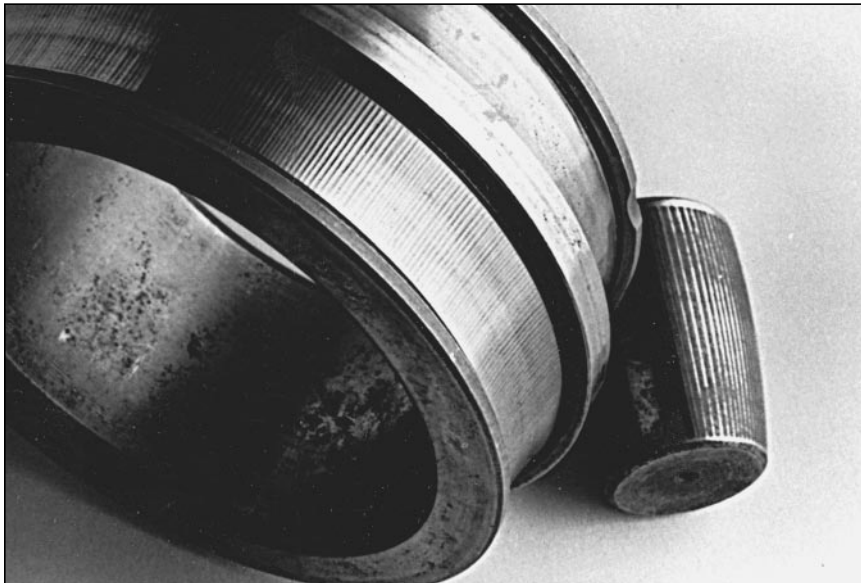

Figure 24 — Fluting, an accumulation of pits, is a sure indicator of bearing currents. Once started, fluting is self-perpetuating until the bearing fails.

path, and the bearing type. The early observable effects of this damage on the bearings is pitting and fluting.

Figure 23 shows a series of electrical pits in a roller and in a raceway of a spherical roller bearing.

More serious electrical damage occurs when current passes during prolonged periods and the number of individual pits accumulates. The result

is fluting, Figure 24. Fluting in anti-friction bearing races specifically indicates the problem is bearing currents. Fluting can occur in ball or roller bearings and develop considerable depth, producing noise and vibration and eventual fatigue from local overstressing. Once fluting is started, it is self-perpetuating until the bearing fails.

Solutions

There are three ways of solving bearing current in any size motor: mechanical shaft grounding, harmonic suppression, and insulating the bearings.

Some third party vendors have attached devices to the shaft with contacting elements that ground it. This is a workable solution, but not the only one or necessarily the best, except for field retrofits.

To control the harmonic content in the power systems, several manufacturers offer line-to-line and line-to-ground sine-wave output and common-mode filters for their adjustable-speed drives. These filters reduce harmonics, audible noise, motor temperature, and vibration, and they increase the life of the motor and its windings. The cost of the filters as well as their tendency to reduce motor-drive efficiency because of extra heat generation determine whether this solution is workable.

Most standard motors in 440 frames and smaller do not have insulated bearings. If bearing currents cause a problem, your motor manufacturer can provide motors with insulated bearings. That is, place an insulating material between the bearing mounting ring and the frame of the motor, or between the shaft and the bearing. Any object in contact with the bearing ring — pipes, tubes, washers, and the bolts used to mount the bearing ring to the frame — must also be insulated.

Insulated bearings are a common option on motors of 580 frame and larger. And it is generally accepted, in the U.S. at least, that adjustable-speed drives and motors above NEMA 440 frames should have insulated bearings to prevent the flow of shaft currents.

It is only necessary to insulate one outboard bearing to open the circuit. Special provisions are necessary in certain cases to maintain an open circuit to the load or another motor, such as insulated drive couplings in large tandem motor arrangements.

Insulating the bearing will not eliminate voltage on the shaft, but it will prevent that voltage from using the bearings as a current path.

Excerpted from an article by Siemens in the May 1996 issue of PTD. ■